

# KAISAI

## MINI VRF



ENERGY-EFFICIENT SOLUTIONS FOR YOUR HOME AND BUSINESS



# WE CARE ABOUT AIR

## Table of Contents

<b>About the Mini VRF R32 System</b>	04
<b>Mini VRF Units</b>	10
<b>Indoor units</b>	20
Cassette units	22
Wall units	26
Duct units	32
<b>Dimensions</b>	36
<b>Controls</b>	40
<b>Accessories</b>	52





We care about the air

VRF systems are **the most advanced and sophisticated** air-to-air **air conditioning systems**, utilizing variable refrigerant flow and direct evaporation of the refrigerant.

Kaisai Mini VRF systems are 2-pipe systems that allow for the connection of up to 9 indoor units. They are an excellent, cost-effective alternative to larger numbers of split and multisplit units. These solutions feature a total installation length of up to 100 m and a height difference of up to 30 m, as well as the ability to oversize the total capacity of the indoor units relative to the outdoor unit by up to 130%.

Kaisai Mini VRF systems are based on outdoor units with horizontal airflow and capacities ranging from 12 to 16 kW. Thanks to a wide range of models, performance parameters, and compact dimensions, they find a broad spectrum of applications in medium-sized commercial and office buildings as well as residential construction.





## Environmentally friendly R32 refrigerant

The use of R32, which has a lower GWP (global warming potential) than R410A, helps reduce the environmental impact. In addition, the same cooling capacity requires a smaller refrigerant charge, which increases efficiency and reduces operating costs.



## Perfect for any space

These compact outdoor units combine high performance with a compact design. Thanks to their well-thought-out design and flexible installation options, they can be installed in confined spaces – such as on rooftops, balconies, or in utility areas – without compromising efficiency.

## A compact solution that offers **maximum capabilities** and flexibility.

Kaisai Mini VRF systems are state-of-the-art HVAC solutions that combine high performance with great design flexibility. They allow for the connection of multiple indoor units while maintaining a compact system footprint, offering extensive adaptability to various types of buildings. Thanks to their ability to operate at low temperatures, effective component cooling, and compatibility with ventilation systems, they ensure reliability and comfort even in demanding conditions.



At most  
9 internal units



Maximum  
capacity - 16 kW



Total length  
installation - 100 m



Refrigerant cooling  
PCB



Working in extremely  
low temperatures



Compatibility  
with air handling  
unit exchangers



## Wide range of system configurations

Kaisai VRF solutions enable the design of advanced HVAC systems with a large number of indoor units featuring a wide range of operating parameters. The system allows for the integration of units with different capacities and types, ensuring high design flexibility and effective adaptation of the installation to the requirements of the building and its occupants.



## Supports **2-9 indoor units**

The system allows for the connection of up to 9 indoor units, providing great design flexibility. Additionally, it permits the total capacity of the indoor units to exceed that of the outdoor unit by up to 130%, allowing the system to be tailored even more closely to actual needs.



## **Flexible** installation options

The system is based on compact outdoor units that combine high performance with a small footprint, allowing for installation in confined spaces.



A. Total length of the installation	100 m
B. Maximum distance between the indoor and outdoor units	55 m
C. Height difference between the indoor unit and the outdoor unit	30 m
D. Height difference between indoor units	10 m
E. Distance from the first branch pipe to the last indoor unit	20 m

# Functions of indoor units



## COLD AIR SUPPLY CONTROL

It prevents cold air from blowing out in heating mode. The indoor unit's fan does not start until the heat exchanger reaches the appropriate temperature, ensuring users enjoy a comfortable indoor climate from the moment the unit starts operating.



## RAPID COOLING / HEATING

Advanced inverter technology allows the desired room temperature to be reached instantly. The air conditioner operates at high efficiency immediately after startup, quickly cooling or heating the interior and ensuring comfortable conditions in a short time.



## MULTIFUNCTIONAL REMOTE CONTROL

The ergonomic wireless remote control allows you to conveniently adjust the temperature, airflow, and operating modes of the air conditioner. Its intuitive design provides quick access to the unit's most important functions.



## SMART DEFROSTING

The intelligent defrosting system automatically initiates the defrosting process only when it is truly necessary. As a result, the air conditioner operates more efficiently, reduces energy consumption, and ensures consistent room heating. This feature enhances user comfort and improves the unit's performance during the winter season.



## INDEPENDENT DEHUMIDIFICATION

The independent dehumidification function effectively reduces excess moisture in the air without the need for intensive cooling of the room. This helps maintain optimal humidity levels, improving daily comfort indoors. Drier air also reduces the feeling of stuffiness and promotes a healthier indoor microclimate.



## FRESH AIR

The ability to supply fresh air to the indoor unit enhances comfort and improves indoor air quality. Constant air exchange helps reduce stuffiness and has a positive effect on occupants' well-being. This solution promotes a healthier and more comfortable indoor environment.



## HIGH-DENSITY FILTER

The high-density filter effectively traps dust, pollen, and fine particles in the air, improving air quality and enhancing user comfort. The increased filtration area boosts cleaning efficiency while protecting the unit from the buildup of contaminants. The filter's simple design makes it easy to clean and maintain on a daily basis.

	Model	WALL-MOUNTED	CASSETTE	DUCT
COMFORT	Cold Air Supply Control	●	●	●
	Rapid cooling / heating	●	●	●
	Multifunction remote control	●	●	x
	Smart defrosting	●	●	●
	Independent dehumidification	●	●	●
HEALTH	Fresh air		●	●
	High-density filter	●		
COMFORT	Wi-Fi Control	x	x	x
	Wired controller	x	x	●
	Central controller	x	x	x
	Digital display	●	●	●
	Two ways draining connection		●	●
	Reverse-flow installation	●		●
ECONOMICS	Sleep function	●	●	●
	Temperature sensor in the remote control	●	●	●

● STANDARD x OPTION

**WI-FI CONTROL**

The Wi-Fi module lets you control your air conditioner from your smartphone or tablet from anywhere with an internet connection. With the app, you can easily adjust the temperature and settings of the unit even when you're away from home.

**WIRED CONTROLLER**

The wall-mounted wired controller provides convenient and reliable control over all air conditioner functions. This solution is ideal for offices, hotels, and other commercial buildings.

**CENTRAL CONTROLLER**

The central controller allows for the simultaneous management of multiple air conditioning units within a single system. This enables users to conveniently control the operating parameters of units in different rooms from a single location.

**DIGITAL DISPLAY**

The modern digital display provides a convenient overview of the unit's key operating parameters. Users can quickly check the temperature, the selected operating mode, and the air conditioner's active functions.

**BUILT-IN CONDENSATE PUMP**

It enables effective condensate drainage even under more demanding installation conditions. This solution makes installation easier and ensures reliable operation of the air conditioner.

**TWO WAYS DRAINING CONNECTION**

The ability to connect the condensate drain on either the left or right side of the unit provides greater flexibility during installation. This feature simplifies the installation of the air conditioner and allows the system to be better adapted to the room's technical conditions.

**SLEEP FUNCTION**

The night mode feature is designed to ensure maximum comfort while you sleep and rest. The air conditioner automatically adjusts the temperature and operating settings, reducing noise and energy consumption. Thanks to its intelligent controls, the unit maintains a comfortable indoor climate throughout the night, ensuring a restful sleep and greater energy efficiency.

**TEMPERATURE SENSOR IN THE REMOTE CONTROL**

The remote control, equipped with a built-in temperature sensor, detects the conditions in the user's vicinity and automatically adjusts the unit's operation. By measuring the temperature closer to the user, the air conditioner can maintain comfortable conditions more precisely and improve operational efficiency.

# Mini VRF R32

Outdoor units



A-Line

**The mini VRF system is based on compact outdoor units that combine high performance with a compact design.**

These compact units are designed to make the most of the available space, making them an ideal solution for both new construction projects and retrofits.

Thanks to their design, these units can be installed in spaces with limited area, such as rooftops, balconies, or utility rooms, without compromising on performance. The advanced technologies used in the outdoor units ensure stable, energy-efficient operation and reliability under various operating conditions, serving as the robust core of the entire air conditioning system.

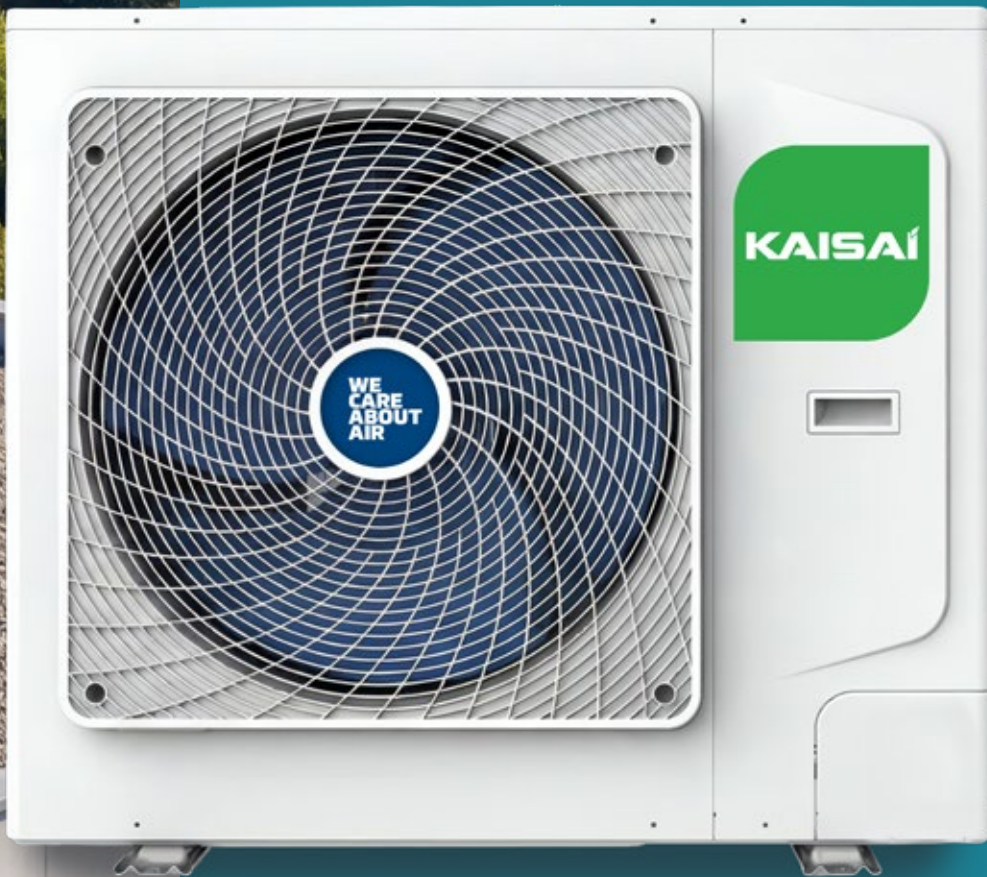



### DC Inverter Compressor

This modern compressor, featuring DC Inverter technology, eliminates electromagnetic losses and reduces the noise typically associated with AC systems. It ensures high energy efficiency, smooth operation, and quiet, stable performance.



### Economy mode 26°C

The 26°C temperature lock feature allows all units to operate in energy-saving mode. This solution helps reduce energy consumption while maintaining user comfort.



### Automatic restart

In the event of a power outage, the device saves the last operating settings. When power is restored, it automatically reverts to the previous settings, ensuring uninterrupted operation without user intervention.

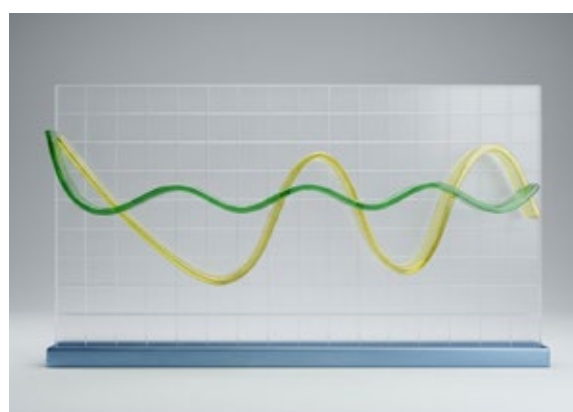

### Precise temperature control

An advanced algorithm monitors temperature fluctuations in the room and continuously optimizes the compressor's operation, ensuring stable conditions and a high level of comfort.



### External refrigerant leak alarm

The system includes an option for a refrigerant leak sensor, which is installed indoors just above the floor. If a refrigerant leak is detected, it immediately triggers an alarm, enhancing safety and protecting the system.



### Built-in refrigerant recovery valve

The integrated valve allows for easy recovery of refrigerant during unit servicing. This solution streamlines installation and maintenance work, enhancing user convenience and minimizing refrigerant loss.



## Smart defrosting

An advanced defrosting algorithm extends the operating time in heating mode and reduces the frequency of defrosting. This helps maintain a stable room temperature and provides greater thermal comfort.



## PCB cooling system using a refrigerant

Effective cooling of electronic components using a refrigerant ensures stable and safe operation of the control system. This solution increases the reliability and service life of the entire system.



## Wide input voltage range

The device is designed to operate stably even under conditions of voltage fluctuations. As a result, it ensures reliable operation in various regions and under different power grid conditions.



## Quiet Mode: Your Comfort

A special operating mode reduces noise levels by approximately 3 dB compared to standard mode. As a result, the device operates quietly and does not disturb the peace and quiet of the surrounding area.



## Rapid cooling and heating

The DC Inverter system quickly reaches full capacity, minimizing temperature fluctuations. This ensures that comfortable conditions are achieved quickly and provides a better user experience.



## Integrated PCB design (2-in-1)

The modern design combines the control board, inverter, and filter into a single module. This simplifies maintenance, reduces the number of components, and improves the unit's reliability.



## Technical Specifications

Model			KVOA120RAA3	KVOA140RAA3	KVOA160RAA3
Capacity	Cooling	kW	12,1	14,0	15,5
	Heating	kW	14,0	16,0	18,0
Electrical specifications	Power supply	V~/Hz/Ph,	380~415 / 50~60 / 3	380~415 / 50~60 / 3	380~415 / 50~60 / 3
	Power consumption for cooling	kW	3,25	3,80	4,80
	EER	W/W	3,72	3,68	3,23
	SEER	W/W	7,03	7,10	6,99
	Power consumption for heating	kW	3,45	3,85	4,60
	COP	W/W	4,06	4,16	3,91
	SCOP	W/W	4,09	5,06	4,60
Characteristics	Airflow	m <sup>3</sup> /h	4840	4840	5100
	Sound pressure	dB(A)	55	56	57
Dimensions (W x D x H)	Net	mm	990×420×860	990×420×860	990×420×860
	Gross	mm	1100×545×980	1100×545×980	1100×545×980
Weight	Net	kg	79	79	79
	Gross	kg	89	89	89
Connection diameter	Liquid	mm (cal)	9,52(3/8)	9,52(3/8)	9,52(3/8)
	Gas	mm (cal)	15,88(5/8)	15,88(5/8)	15,88(5/8)
	Maximum installation length	m	100	100	100
	Max. height of outer unit – inner unit	m	30	30	30
Ambient temperature (cooling/heating)		°C	-15~49/-20~24	-15~49/-20~24	-15~49/-20~24
Type / amount of refrigerant	Type		R32	R32	R32
	Amount filled	kg	3,40	3,40	3,40
Range of the IDU/ODU performance ratio		%	50 ~ 130	50 ~ 130	50 ~ 130

### Notes:

The manufacturer reserves the right to change all technical specifications without prior notice.

# Indoor units

Indoor units

A-Line





**The indoor units of the Kaisai Mini VRF system are designed to adapt flexibly to various types of buildings and user requirements. The wide range of models allows you to choose the optimal solution in terms of both functionality and aesthetics.**

These units offer high energy efficiency and stable operation in both cooling and heating modes. Advanced control systems allow for individual climate management in each room. The units are distinguished by their quiet operation and high level of comfort.

The technologies used ensure the reliability and durability of the entire system. Kaisai Mini VRF solutions offer a modern response to the needs of today's HVAC systems.



MINI VRF

# Compact Cassette

KVUA 028/036/045/056 RAA1

Cassette units are designed for installation in suspended ceilings, allowing the unit to be discreetly concealed and making optimal use of space. With air discharge in four directions, they ensure even temperature distribution throughout the room.



CHECK OUT AND COMPARE THIS DEVICE WITH OTHERS  
 YOU CAN FIND ALL THE FEATURES ON PAGES 10-11

Compact cassette units are characterized by high efficiency and quiet operation, making them an ideal solution for offices, conference rooms, and commercial facilities. Modern controls allow for precise adjustment of operating parameters to the user's current needs. The technologies used improve user comfort and the system's energy efficiency. The design of the units facilitates service and maintenance, reducing the time required for technical support.



### High airflow

The optimized design of the ring and its installation depth, developed using simulation, ensure high airflow and enhance comfort during both cooling and heating



### Easy removal of the fan turbine

Because the electronics box is located outside the housing, the fan turbine can be quickly removed after taking off the air guide ring, which significantly simplifies maintenance and after-sales service

## Fresh air and 360° airflow

The air conditioner can bring in fresh air from outside, which improves indoor air quality. Additionally, the unit provides 360° air circulation, which distributes air evenly. Regular air exchange and optimal air distribution ensure a healthier and more comfortable environment, promoting better well-being and concentration.



### External electronics box

This design, which provides easy access for service, eliminates the need to remove the unit, significantly simplifying and speeding up maintenance, service, and after-sales support.



### Built-in condensate pump

The integrated condensate pump enables efficient condensate drainage even when gravity drainage is limited, which increases installation flexibility and makes it easier to install the unit in a variety of conditions. The pump has a lift height of 120 cm.



## Technical Specifications

Model			KVUA028RAA1 KWAMB09A	KVUA036RAA1 KWAMB09A	KVUA045RAA1 KWAMB09A	KVUA056RAA1 KWAMB09A
Capacity	Cooling	kW	2,8	3,6	4,5	5,6
	Heating	kW	3,0	4,3	5,0	6,3
Electrical specifications	Power supply	V~/Hz/Ph	220~240 / 50~60 / 1220~240 / 50~60 / 1220~240 / 50~60 / 1220~240 / 50~60 / 1			
	Power	W	30	30	30	30
Characteristics	Airflow (high/medium/low)	m <sup>3</sup> /h	765/670/625	765/670/625	765/670/625	765/670/625
	Sound pressure (high/mid/low)	dB(A)	39/36/32	39/36/32	39/36/32	39/36/32
Dimensions (W x D x H)	Net	mm	570×570×260	570×570×260	570×570×260	570×570×260
	Gross	mm	720×650×290	720×650×290	720×650×290	720×650×290
	Netto (Panel)	mm	650×650×55	650×650×55	650×650×55	650×650×55
	Gross (Panel)	mm	710×710×80	710×710×80	710×710×80	710×710×80
Weight	Net/Gross	kg	15,0/18,0	15,0/18,0	15,0/18,0	15,0/18,0
	Net/Gross (Panel)	kg	2,2/3,7	2,2/3,7	2,2/3,7	2,2/3,7
Type of refrigerant			R32/R410A	R32/R410A	R32/R410A	R32/R410A
Connection diameter	Liquid	mm (inches)	6,35 (1/4)	6,35 (1/4)	6,35 (1/4)	6,35 (1/4)
	Gas	mm (inches)	12,7 (1/2)	12,7 (1/2)	12,7 (1/2)	12,7 (1/2)
	Condensate	mm (inches)	DN20 (3/4)	DN20 (3/4)	DN20 (3/4)	DN20 (3/4)

# Wall-mounted

KVWA 022/028/036/045/056/071 RAA1

Wall-mounted units are a versatile solution designed for a variety of spaces, such as offices, commercial premises, and residential areas. Their compact build and modern design make them easy to integrate into any interior.



CHECK OUT AND COMPARE THIS DEVICE WITH OTHERS  
 YOU CAN FIND **ALL THE FEATURES ON PAGES 10-11**

These units provide efficient cooling and heating while maintaining low noise levels. Advanced control features allow for convenient management of the system, including temperature and operating mode adjustments. The units are equipped with air quality improvement solutions, which translate into greater user comfort. Simple installation and service access make them a popular choice for smaller-scale installations. The unit comes standard with a wireless remote control; a wired controller is available as an option.



### Cold Air Supply Control

To minimize the sensation of an unpleasantly cool airflow, the air conditioner automatically reduces the fan speed when it starts operating in heating mode and increases it as the air warms up.



### Smart temperature adjustment

The remote control with a temperature sensor detects the conditions in the user's environment and automatically adjusts the device's operation. This allows for precise maintenance of a comfortable temperature and improves operational efficiency.



## 4D Airflow **Comfort Control**

Air is distributed evenly throughout the room, ensuring consistent comfort. The 4D airflow directs the airflow both vertically and horizontally, eliminating temperature variations and improving air circulation.

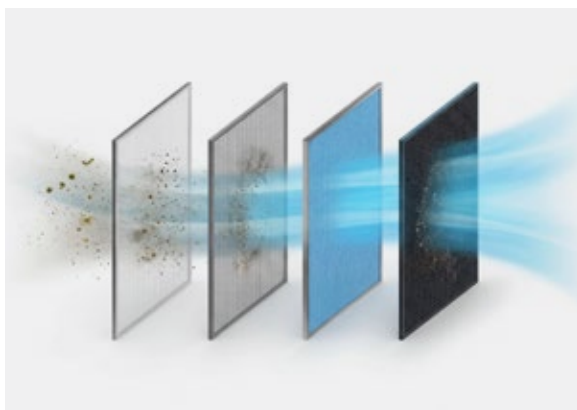

### Advanced air filtration

The high-density filter effectively removes dust, pollen, and fine particles, improving indoor air quality. Its large filtration surface area enhances efficiency, and its simple design makes it easy to clean.



### Protection using nanotechnology

Integrated nano-scale protective foam enhances moisture resistance and improves thermal insulation. This solution ensures stable operation of the device and increases its durability and energy efficiency.



### Flexible wired control

The standard wireless remote control can be supplemented with an optional wall-mounted wired controller. This solution prevents the remote from getting lost and is particularly well-suited for commercial spaces, providing convenient and reliable control of the device.



### Wi-Fi Control

The built-in Wi-Fi feature allows you to control the unit remotely from your smartphone. You can conveniently adjust the temperature and operating modes, and monitor the air conditioner's performance from anywhere.



### Two ways draining connections

The ability to connect the condensate drain on either the left or right side of the unit makes it easier to adapt the installation to the specific installation conditions. This flexible solution reduces installation time and makes the installer's job easier.



### Quick installation and easy maintenance

Clear installation markings and a built-in spirit level make it easy to position the unit precisely. Removable housing components and a well-thought-out design provide easy access to the connections, streamlining installation and maintenance.

# Technical Specifications

Model			KVWA022RAA1	KVWA028RAA1	KVWA036RAA1
Capacity	Cooling	kW	2,2	2,8	3,6
	Heating	kW	2,5	3,2	4,0
Electrical specifications	Power supply	V~ / Hz / Ph	220~240 / 50~60 / 1	220~240 / 50~60 / 1	220~240 / 50~60 / 1
	Power	W	27	27	27
Characteristics	Airflow (high/medium/low)	m <sup>3</sup> /h	545/460/435	545/460/435	545/460/435
	Sound pressure (high/mid/low)	dB(A)	37/34/32	37/34/32	37/34/32
Dimensions (W x H x D)	Net	mm	834×299×202	834×299×202	834×299×202
	Gross	mm	891×371×282	891×371×282	891×371×282
Weight	Net/Gross	kg	9,5/11,5	9,5/11,5	9,5/11,5
Type of refrigerant			R32/R410A	R32/R410A	R32/R410A
Connection diameter	Liquid	mm (in.)	6,35(1/4)	6,35(1/4)	6,35(1/4)
	Gas	mm (inches)	9,52(3/8)	9,52(3/8)	9,52(3/8)
	Condensate	mm (inches)	DN16 (1/2)	DN16 (1/2)	DN16 (1/2)

Model			KVWA045RAA1	KVWA056RAA1	KVWA071RAA1
Capacity	Cooling	kW	4,5	5,6	7,1
	Heating	kW	5,0	6,3	8,0
Electrical specifications	Power supply	V~ / Hz / Ph	220~240 / 50~60 / 1	220~240 / 50~60 / 1	220~240 / 50~60 / 1
	Power	W	40	40	50
Characteristics	Airflow (high/medium/low)	m <sup>3</sup> /h	815/685/590	815/685/590	1110/990/835
	Sound pressure (high/mid/low)	dB(A)	41/35/30	41/35/30	44/41/37
Dimensions (W x H x D)	Net	mm	997×312×222	997×312×222	1145×331×230
	Gross	mm	1070×385×327	1070×385×327	1210×400×327
Weight	Net/Gross	kg	12,0/15,0	12,0/15,0	12,0/15,0
Type of refrigerant			R32/R410A	R32/R410A	R32/R410A
Connection diameter	Liquid	mm (inches)	6,35(1/4)	6,35(1/4)	6,35(1/4)
	Gas	mm (in.)	12,7(1/2)	12,7(1/2)	12,7(1/2)
	Condensate	mm (in.)	DN16 (1/2)	DN16 (1/2)	DN16 (1/2)

**Notes:**

1. Cooling capacity: indoor temperature 27°C DB/19°C WB, outdoor temperature 35°C DB/24°C WB
2. Heating capacity: indoor temperature 20°C DB, outdoor temperature 7°C DB/6°C WB
3. Length of the refrigeration system: 7.5 m. Height difference: 0 m.
4. Noise levels are measured at a distance of 1.4 meters below the unit
- 5 The manufacturer reserves the right to change all technical specifications without prior notice

# Duct

KVRA 022/028/036/045/056/071 RAA1

Duct units are designed for systems that require discreet installation and individual air distribution via a duct network. They allow for the simultaneous cooling of multiple rooms while maintaining a uniform interior aesthetic, with no visible equipment.



CHECK OUT AND COMPARE THIS DEVICE WITH OTHERS  
 YOU CAN FIND ALL THE FEATURES ON PAGES 10-11

Thanks to their adjustable pressure, duct units allow for flexible ventilation system design. They are highly efficient and offer precise control over operating parameters. The units operate quietly, which is particularly important in office and hotel spaces. This solution ensures high user comfort while maintaining full control over air distribution. The unit comes standard with a wired controller.

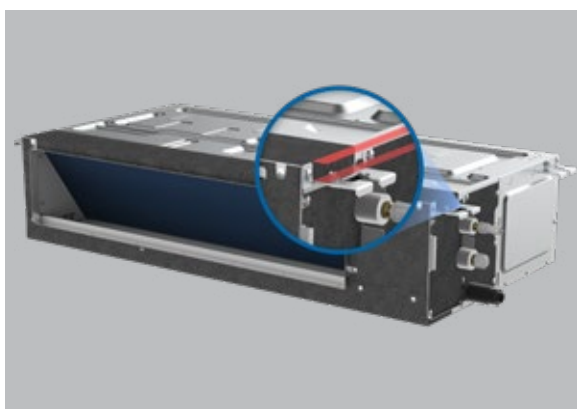

### Ergonomic mounting brackets

The well-designed mounting brackets ensure adequate clearance between the lifting sling and the top cover of the unit, making it easier to lift and install. This makes installation faster, more convenient, and less strenuous, even in challenging installation conditions.



### New, reinforced design

The device's optimized structure was developed based on advanced simulation analyses, which has increased its strength and resistance to deformation. Its robust construction ensures safety during transport and long-term, reliable operation under various operating conditions.

## Clean air, better well-being

A specially designed fresh air intake ensures that fresh air is effectively supplied to the air conditioner. This solution provides a constant supply of fresh air, improving user comfort and the quality of the indoor environment.

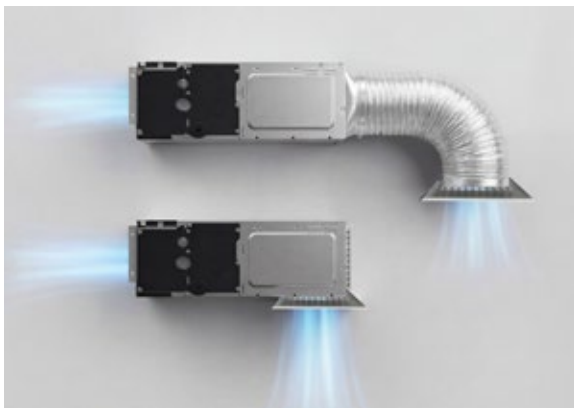

### Flexible air return options

The unit offers two air return options – rear and bottom – allowing the installation to be tailored to the specific requirements of the space. The ability to change the configuration by removing the bottom panel provides greater design flexibility and facilitates integration with the ventilation system.

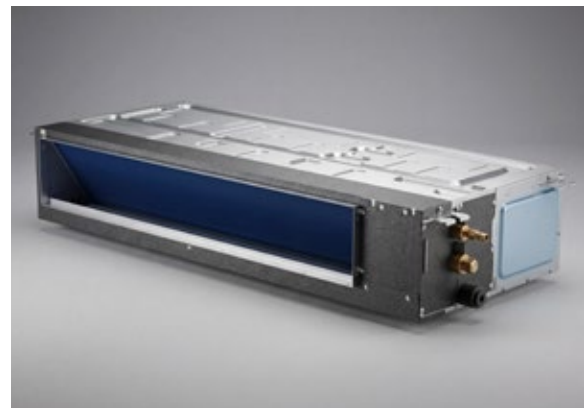

### Built-in electronics box

The integrated electronics box makes installation easier and keeps the components inside the unit neatly organized. The increased amount of insulation improves safety and durability, while also facilitating service access and streamlining the connection process.

# Technical Specifications

Model			KVRA022RAA1	KVRA028RAA1	KVRA036RAA1
Capacity	Cooling	kW	2,2	2,8	3,6
	Heating	kW	2,5	3,2	4,0
Electrical specifications	Power supply	V~/Hz/Ph	220~240 / 50~60 / 1	220~240 / 50~60 / 1	220~240 / 50~60 / 1
	Power	W	28	28	31
Characteristics	Airflow (high/medium/low)	m <sup>3</sup> /h	460/400/340	460/400/340	605/500/430
	Sound pressure (high/mid/low)	dB(A)	30/26/22	30/26/22	30/28/24
	Available pressure (ESP)	Bye	13(0~50)	13(0~50)	13(0~50)
Dimensions (W x D x H)	Net	mm	550×450×198	550×450×198	700 x 450 x 198
	Gross	mm	715×535×255	715×535×255	865×535×255
Weight	Net/Gross	kg	11,0/13,5	11,0/13,5	13,0/16,0
Type of refrigerant			R32/R410A	R32/R410A	R32/R410A
Connection diameter	Liquid	mm (inches)	6,35(1/4)	6,35(1/4)	6,35(1/4)
	Gas	mm (in.)	9,52(3/8)	9,52(3/8)	12,7(1/2)
	Condensate	mm (inches)	DN25 (1)	DN25 (1)	DN25 (1)

Model			KVRA045RAA1	KVRA056RAA1	KVRA071RAA1
Capacity	Cooling	kW	4,5	5,6	7,1
	Heating	kW	5,0	6,3	8,0
Electrical specifications	Power supply	V~/Hz/Ph	220~240 / 50~60 / 1	220~240 / 50~60 / 1	220~240 / 50~60 / 1
	Power	W	58	58	65
Characteristics	Airflow (high/medium/low)	m <sup>3</sup> /h	900/750/600	900/750/600	1145/945/700
	Sound pressure (high/mid/low)	dB(A)	35/30/26	35/30/26	36/32/28
	Available pressure (ESP)	Bye	13(0~50)	13(0~50)	13(0~50)
Dimensions (W x D x H)	Net	mm	900×450×198	900×450×198	1100×450×198
	Gross	mm	1065×535×255	1065×535×255	1265×535×255
Weight	Net/Gross	kg	15,5/18,5	15,5/18,5	18,5/21,5
Type of refrigerant			R32/R410A	R32/R410A	R32/R410A
Connection diameter	Liquid	mm (inches)	6,35(1/4)	6,35(1/4)	9,52(3/8)
	Gas	mm (inches)	12,7(1/2)	12,7(1/2)	15,88(5/8)
	Condensate	mm (inches)	DN25 (1)	DN25 (1)	DN25 (1)

**Notes:**

1. Cooling capacity: indoor temperature 27°C DB/19°C WB, outdoor temperature 35°C DB/24°C WB
2. Heating capacity: indoor temperature 20°C (dry bulb), outdoor temperature 7°C (dry bulb)/6°C (wet bulb)
3. Length of the refrigeration system: 7.5 m. Height difference: 0 m.
4. Noise levels are measured at a distance of 1.4 m below the unit
- 5 The manufacturer reserves the right to change all technical specifications without prior notice

# Dimensions

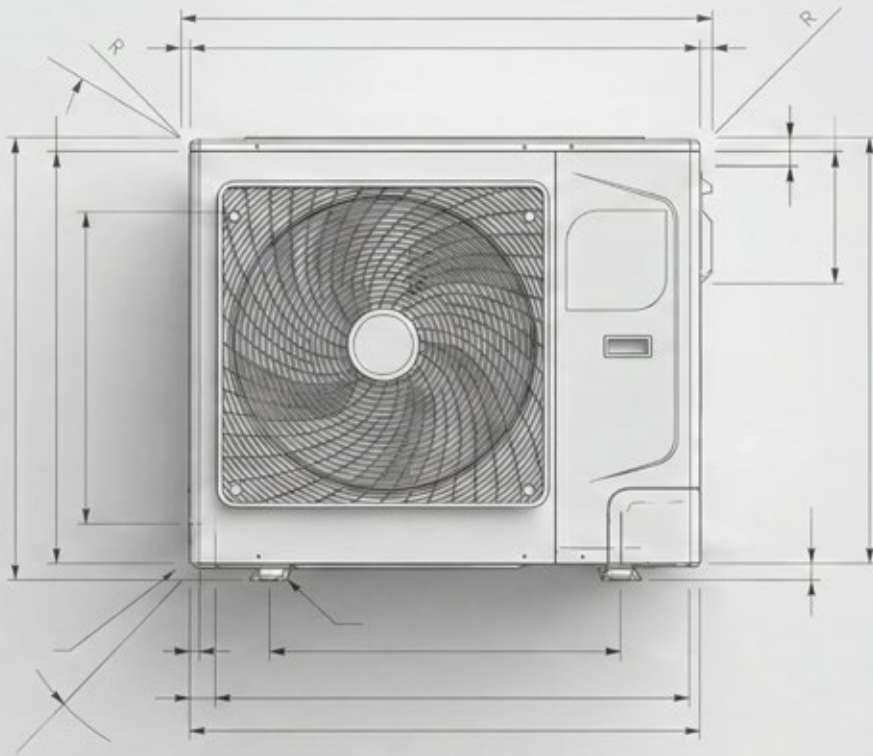

## Dimensions of outdoor units

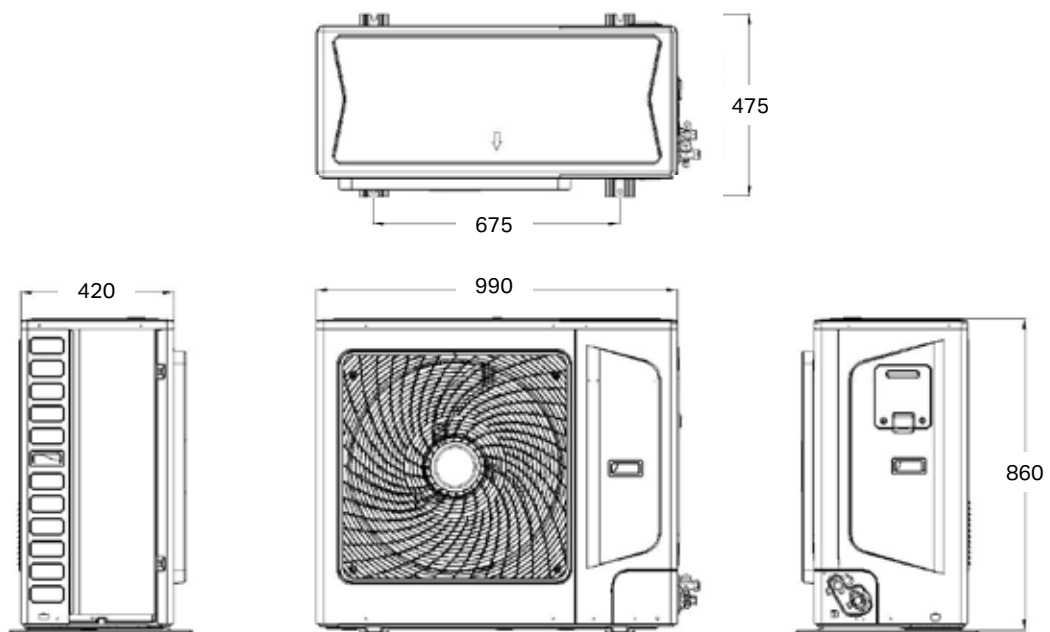

# Dimensions of cassette units

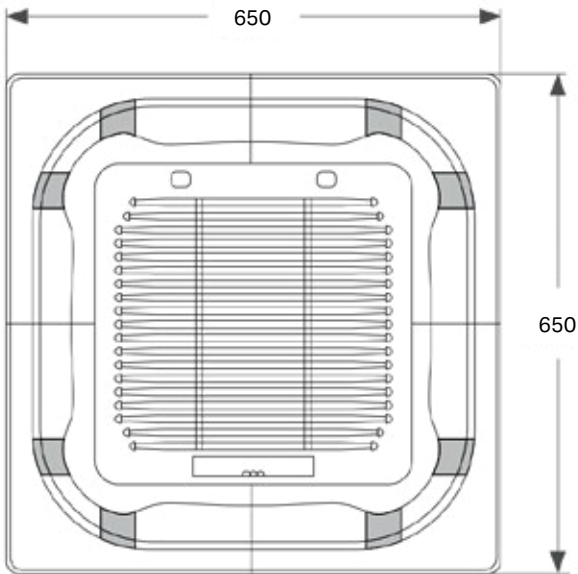
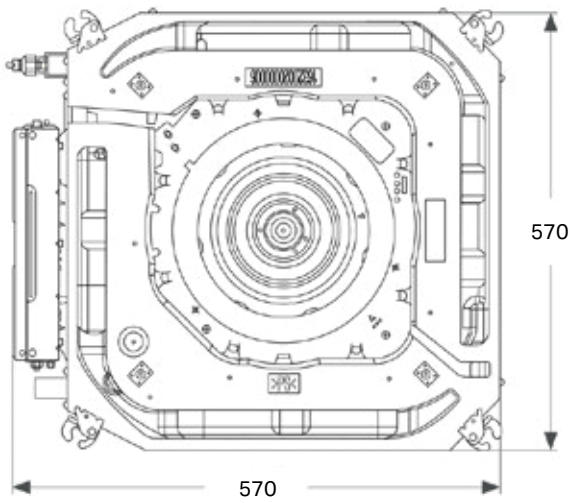
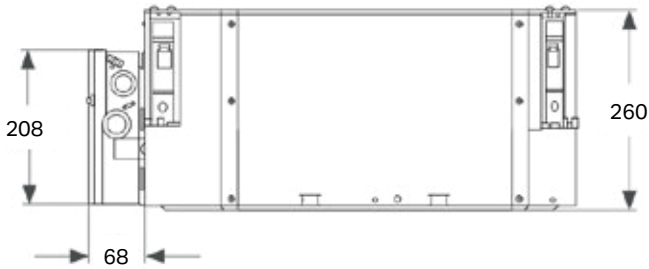

## Dimensions of wall-mounted units

KVWA 022/028/036 RAA1

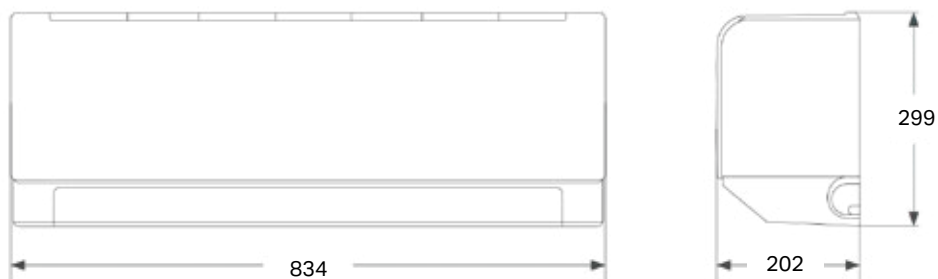

KVWA 045/056 RAA1

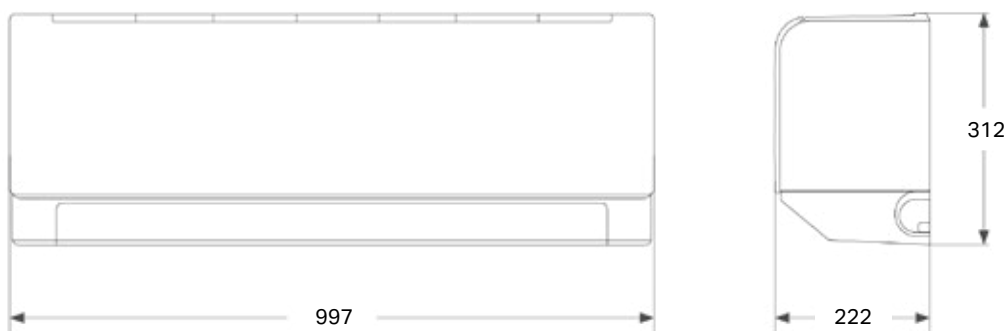

KVWA 071 RAA1

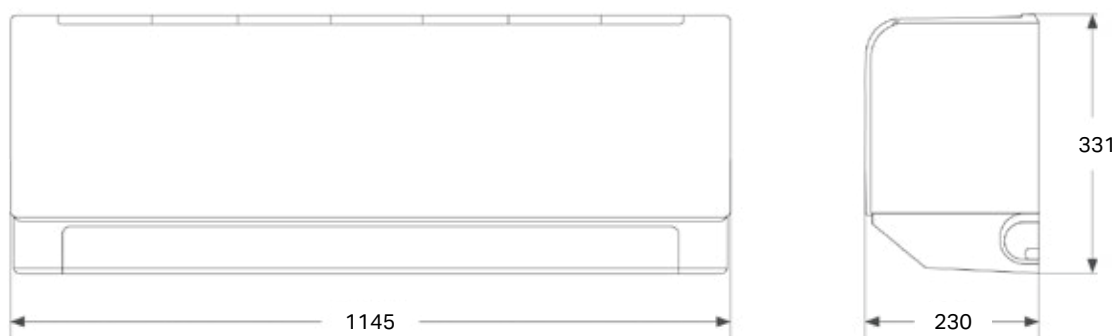

# Dimensions of duct units

KVRA022RAA1 / KVRA028RAA1

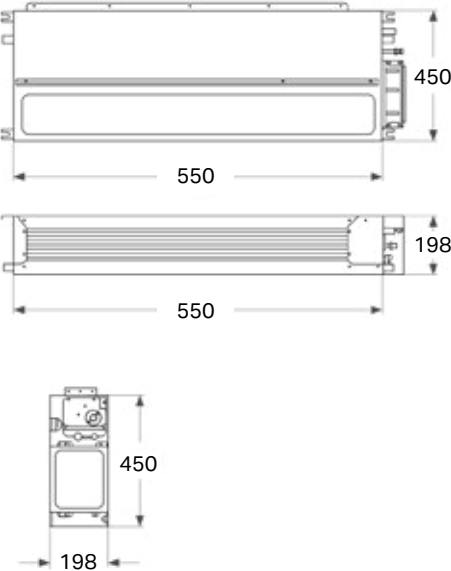

KVRA036RAA1

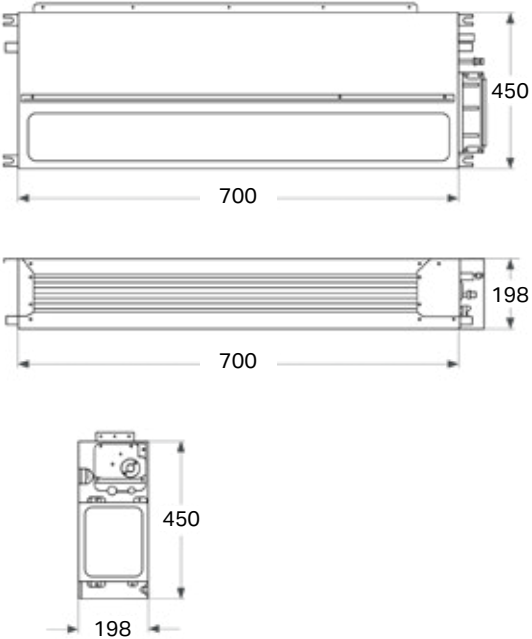

KVRA045RAA1 / KVRA056RAA1

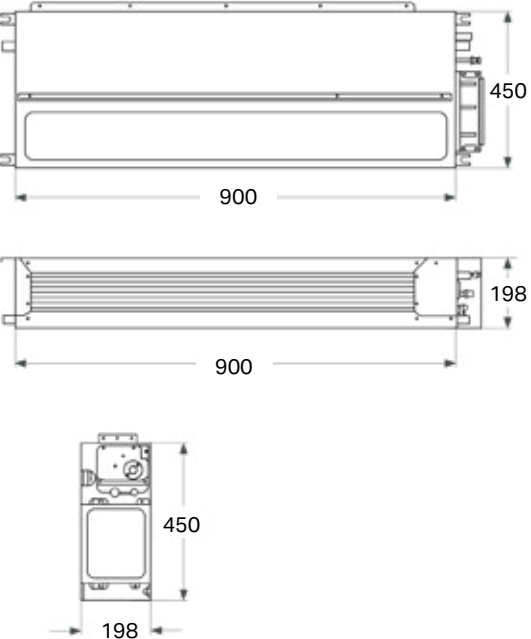

KVRA071RAA1

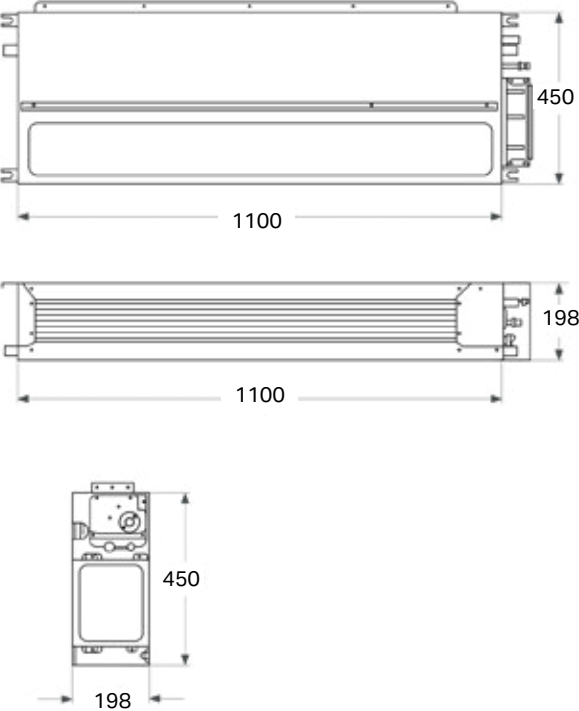

# Controls

## Precise control **for your comfort**

Enhanced measurement and control precision, thanks to advanced automation, enables precise management of the building's HVAC system. An easy-to-read and intuitive controller, clear menus, and straightforward function descriptions make it convenient and efficient to control the HVAC system on a daily basis.



# Wireless controls



## The AC Freedom mobile app

Kaisai air conditioners offer not only advanced cooling and heating technology, but also full integration with a modern lifestyle. With the ability to connect to smart devices via Wi-Fi or GSM, users gain the freedom to control the climate in their home or office – wherever they are and whenever they need to. All you need is a smartphone or tablet (iPhone, iPad, Android) to adjust the unit's settings to your current needs with a single tap.

The dedicated mobile app gives you full control over the air conditioner: it lets you change the operating mode, adjust the temperature precisely, control the airflow (swing), and set timers. Users can also create their own operating schedules tailored to their daily routine.

In addition, the scene mode feature lets you activate optimal settings with a single click – perfect for sleeping, working, or relaxing. It's a smart solution that enhances comfort, saves energy, and ensures your air conditioner works exactly the way you need it to.

# Wireless remote controls



## KWAYK-L remote control

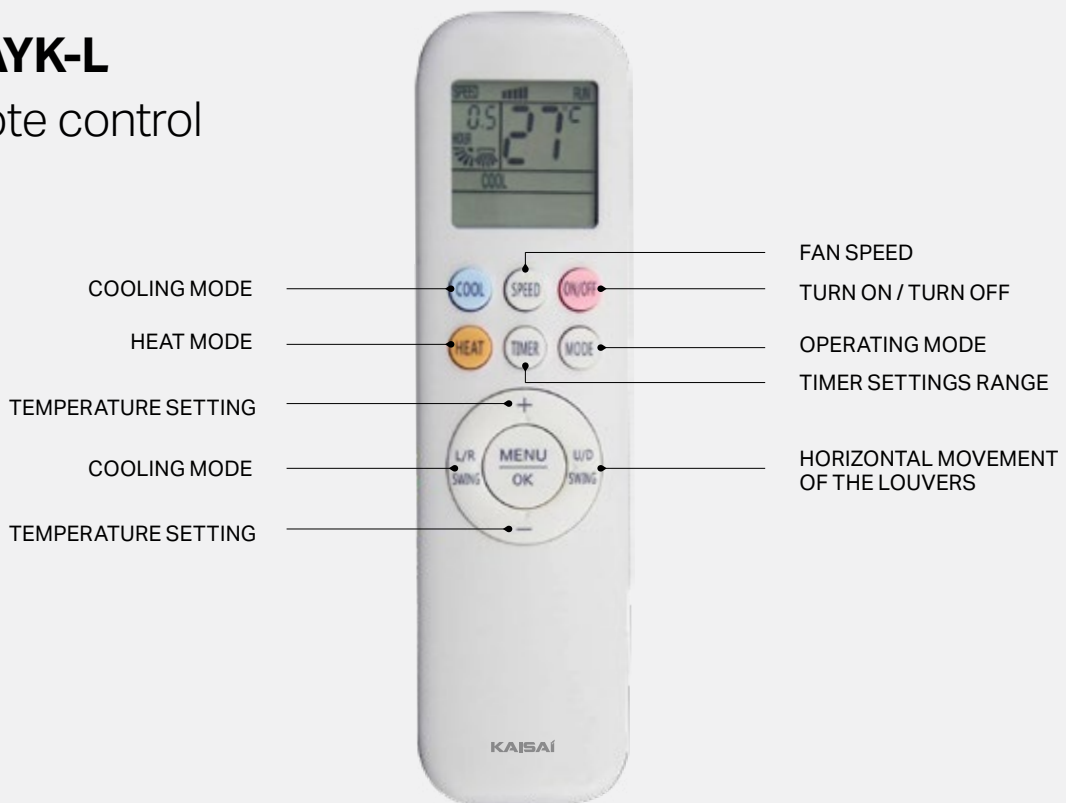

## Backlit remote control screen

The screen backlight ensures convenient and intuitive operation of the device, even in dimly lit or dark rooms. It activates automatically when a button is pressed. After use or a short period of inactivity, the backlight turns off automatically, which helps reduce energy consumption and enhances user comfort, especially at night.

## Technical Specifications

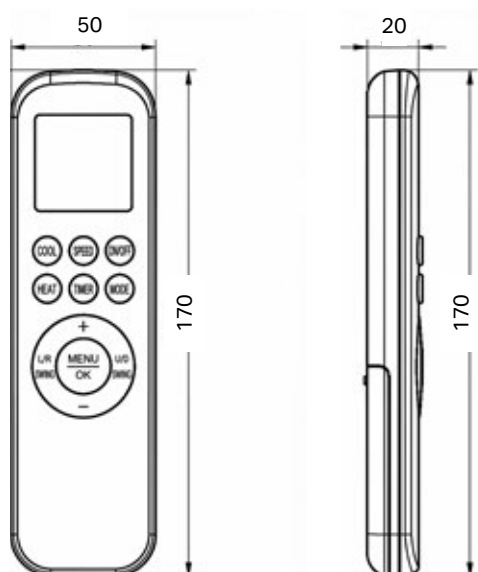

# Wired controls

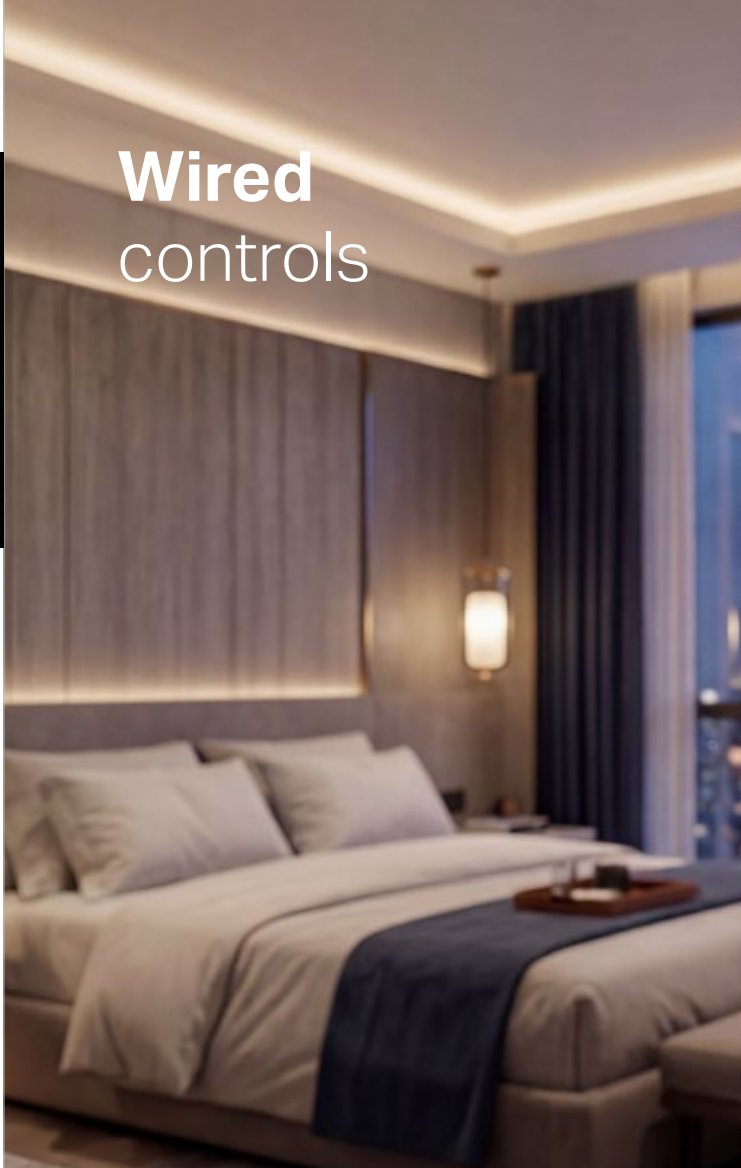

## KWAXK-05A controller



FAN SPEED  
TIMER BUTTON  
  
FUNCTION BUTTON  
ADJUSTMENT BUTTON

BLIND SETTINGS  
MODE SWITCHING  
  
TURN ON / TURN OFF  
ADJUSTMENT BUTTON

## Built-in timer

The built-in timer allows the system to turn on and off automatically according to a preset daily schedule. Users can adjust the air conditioning to match the facility's operating hours without the need for manual intervention. This solution enhances user comfort, saves energy, and ensures optimal indoor conditions exactly when they are needed.



### Controller signal receiver

The controller features a built-in signal receiver that allows the system to be operated using either the wired controller or the wireless remote control. This solution enhances user convenience and enables quick adjustment of operating parameters without having to approach the device.



### Setting addresses

The address configuration feature simplifies system installation and subsequent maintenance by allowing addresses to be quickly assigned to individual units. A service technician can conveniently set the indoor unit's address directly from the controller, which speeds up the process and reduces the risk of errors. It is also possible to automatically address the entire system from the outdoor unit.



## Backlit controller screen

The screen backlight ensures convenient and intuitive operation of the device, even in dimly lit or dark rooms. It activates automatically when a button is pressed. After use or a short period of inactivity, the backlight turns off automatically, which helps reduce energy consumption and enhances user comfort, especially at night.



### Error messages

If a fault occurs, corresponding error codes appear on the controller screen in a dedicated section of the interface. This facilitates quick identification of the problem and significantly speeds up the system diagnostics and repair process, minimizing equipment downtime.



### Keyboard lock

The lock function prevents accidental or unauthorized changes to settings by third parties, especially in public places. This makes it possible to maintain the device's preset operating parameters and increase control over the system, which translates to greater safety and operational stability.



## Function Follow Me

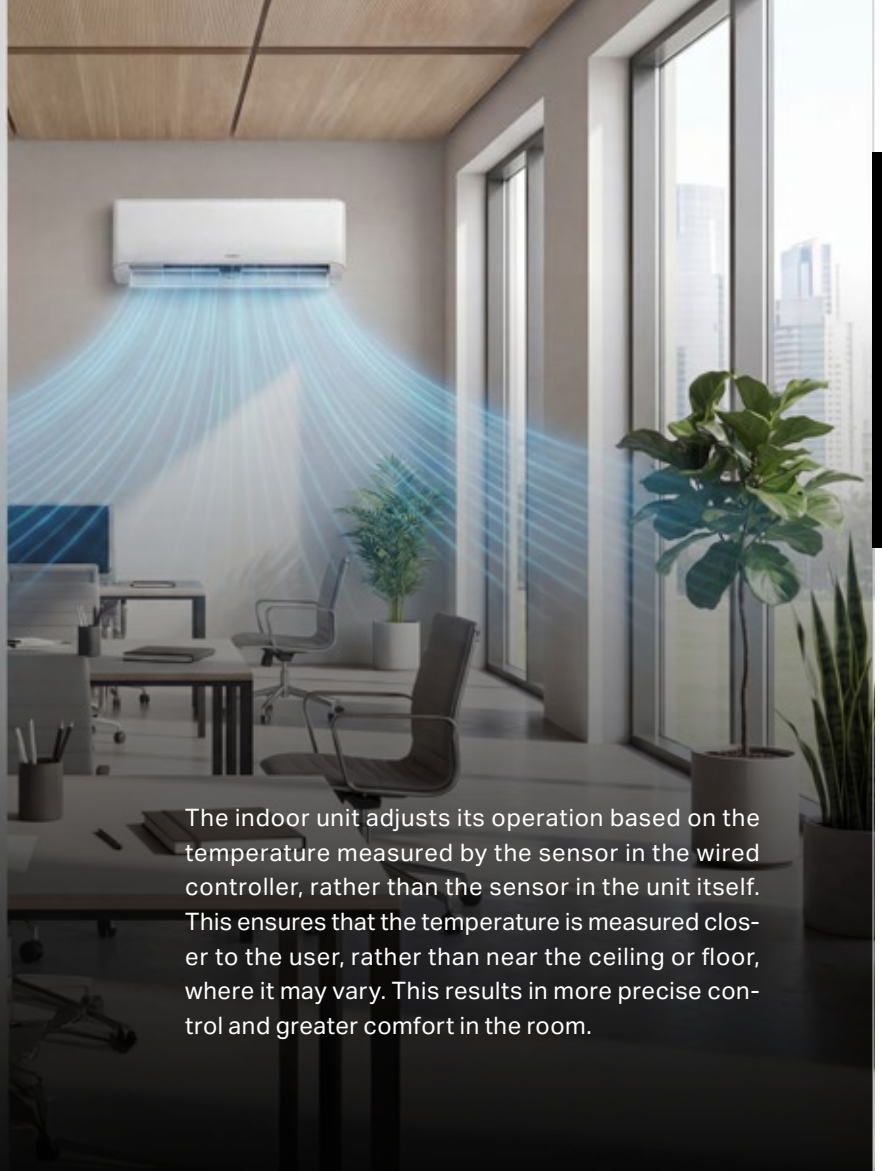

The indoor unit adjusts its operation based on the temperature measured by the sensor in the wired controller, rather than the sensor in the unit itself. This ensures that the temperature is measured closer to the user, rather than near the ceiling or floor, where it may vary. This results in more precise control and greater comfort in the room.

## Technical Specifications

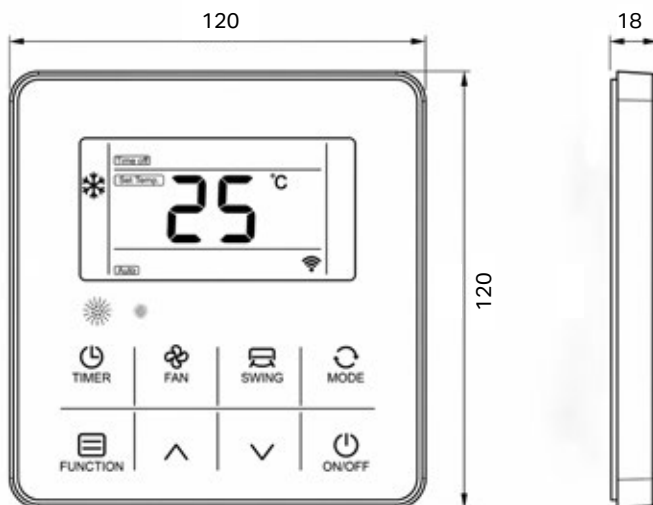

# Central controls



Kaisai central controllers enable comprehensive management of multiple air conditioning units from a single location. This solution is designed for larger installations, such as office buildings, hotels, and commercial facilities. Thanks to central control, users can monitor and control the operation of all connected units in real time, which significantly simplifies system operation. The controllers allow for the adjustment of operating parameters, such as mode, temperature, or operating schedules for individual zones or devices. The system supports energy consumption optimization, improves system efficiency, and facilitates maintenance management by enabling the quick identification of potential faults and their efficient resolution.



## Touchscreen control

The touchscreen central controller is an advanced, multifunctional device capable of managing up to 256 indoor units simultaneously, with a maximum installation length of 1,000 meters. It provides convenient, intuitive control of the entire system from a single location.



## Multi-level lock function

The modern central controller offers extensive security options. It not only allows you to lock the controller's keypad, but also enables users to disable specific operating modes for individual units or restrict the functionality of their remote controls, thereby increasing control over the system.

## Control of multiple systems

The device allows for the simultaneous management of up to 256 indoor units from various external systems, provided they have unique addresses. This significantly increases installation flexibility and minimizes system limitations.



### Weekly work schedule

The weekly scheduler function allows you to set up to four time slots per day. Each slot can be assigned its own operating mode and temperature, enabling you to precisely tailor the system's operation to your daily routine.



### Status of indoor units

The central controller allows users to view error and safety codes directly on its screen, without having to check the PCBs of external units. Additionally, users can review the history of events and codes, which facilitates diagnostics and assessment of the system's condition before calling for service.

## Central Controller and Connections (Mini VRF)

Central controllers in the Mini VRF system can be connected directly to the outdoor unit (master) or to any indoor unit within the system. This solution significantly simplifies wiring configuration, reducing its complexity and shortening installation time.

The flexibility of the connection allows the system to be easily adapted to the specific characteristics of the facility and facilitates future expansion. Thanks to the simplified installation architecture, the reliability of the entire system is enhanced and installers' work is made easier, which results in faster commissioning and more efficient management of the air conditioning system.

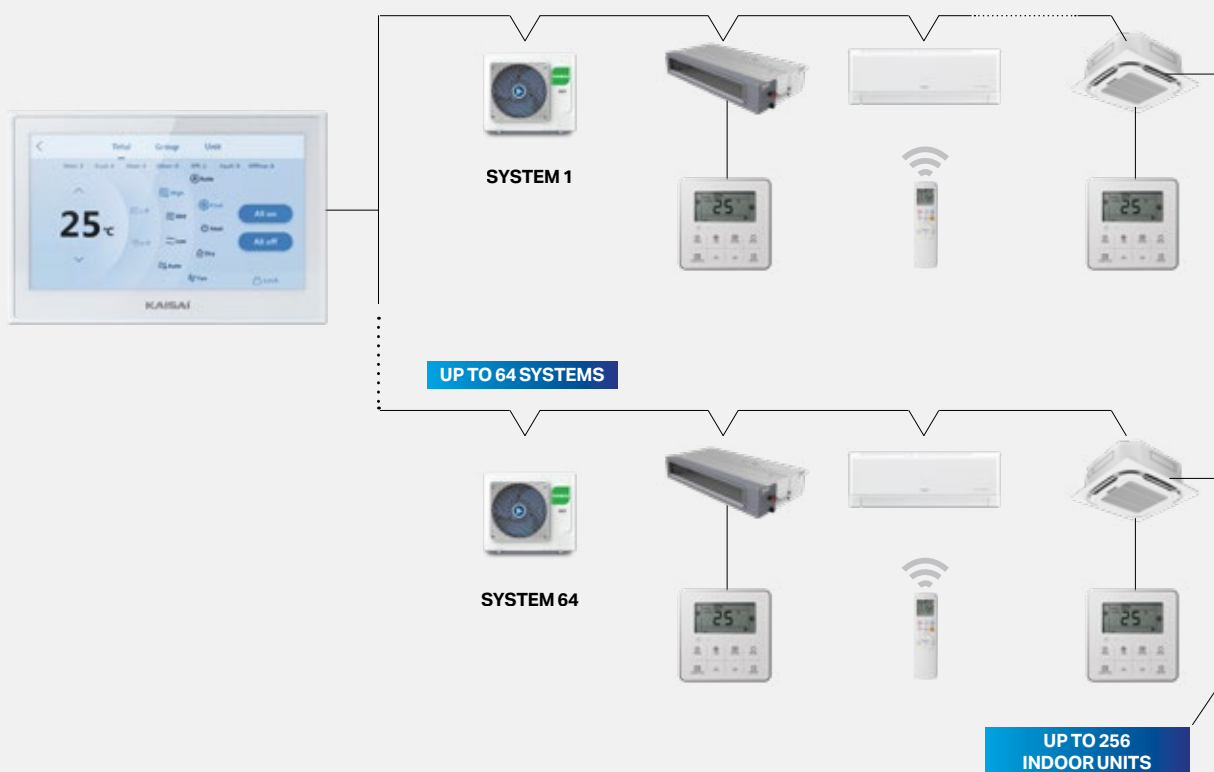

<p><b>Model</b></p>	<p><b>KWAKZB-DL</b></p> 
<p>Dimensions (W x H x D) [mm]</p>	<p>176×116×12</p>
<p>Electrical specifications</p>	<p>AC 180–240 V (50/60 Hz)</p>

# BMS System

The R32 MINI VRF system is equipped with an integrated communication gateway, which eliminates the need for additional external devices. This enables a direct and seamless connection to the BMS (Building Management System), significantly simplifying integration with the building's infrastructure. This solution not only reduces installation costs and minimizes the number of components but also enhances the reliability of the entire system.

## System diagram

The built-in gateway enables centralized management, monitoring, and optimization of the HVAC system's operation in real time. Thanks to integration with building management systems (BMS), users gain full control over all operating parameters, as well as the ability to respond quickly to changing conditions and the facility's needs. This solution improves energy efficiency, streamlines system monitoring, and simplifies maintenance planning. It is the ideal choice for modern commercial and office buildings, where reliability, ease of use, and comprehensive management of building technical systems are of paramount importance.

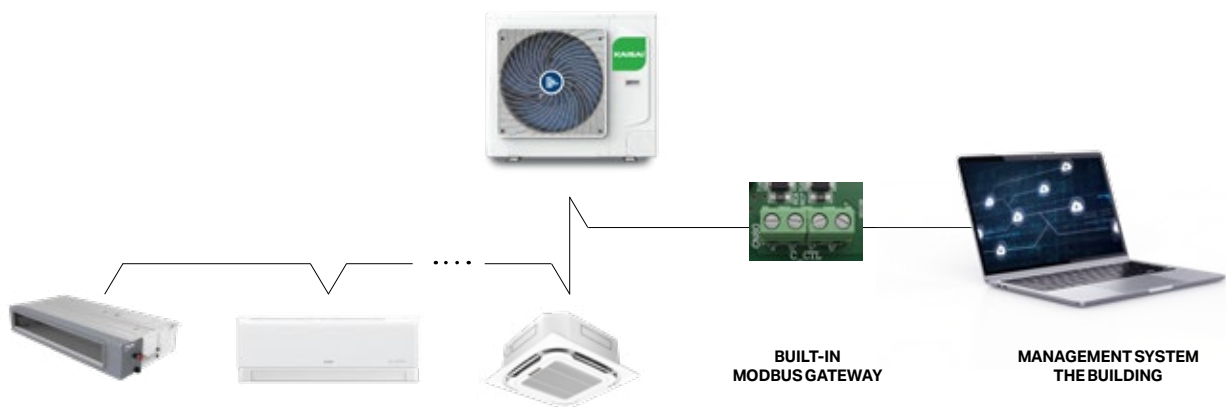



# Monitoring software

Advanced monitoring software is a modern tool that supports both the installation and ongoing maintenance of air conditioning systems. Thanks to its self-diagnostic capabilities, it can function as a remote control, making it particularly useful during the commissioning phase.

The software enables real-time monitoring of outdoor and indoor units, providing full control over the system's operating parameters. In the event of a malfunction, it automatically identifies and displays errors, which significantly simplifies the diagnostic process. Thanks to its intuitive interface and quick access to key information, the software speeds up fault detection and streamlines service work. It provides reliable support for installers and technicians, helping to increase work efficiency, reduce response times, and ensure optimal operation of the entire system.



## Installation diagram

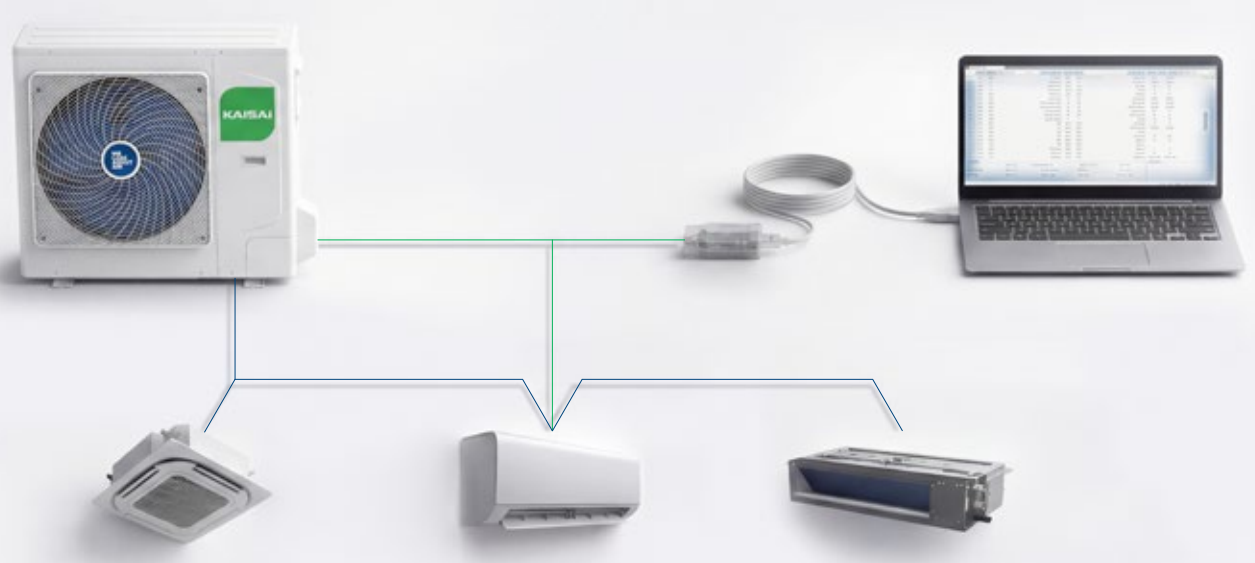

# Refrigerant leak detector (optional)

The refrigerant leak detector is installed inside the building and monitors the concentration of refrigerant in the actual leakage area. If a refrigerant leak occurs, the detector emits an audible and visual alarm signal to indicate the risk of refrigerant accumulation. The indoor unit is equipped as standard with a refrigerant shut-off valve. Once activated by the alarm, the outdoor unit automatically recovers the refrigerant to prevent further leakage.



Connection diagram for the refrigerant leak detector when connected directly to the indoor unit.

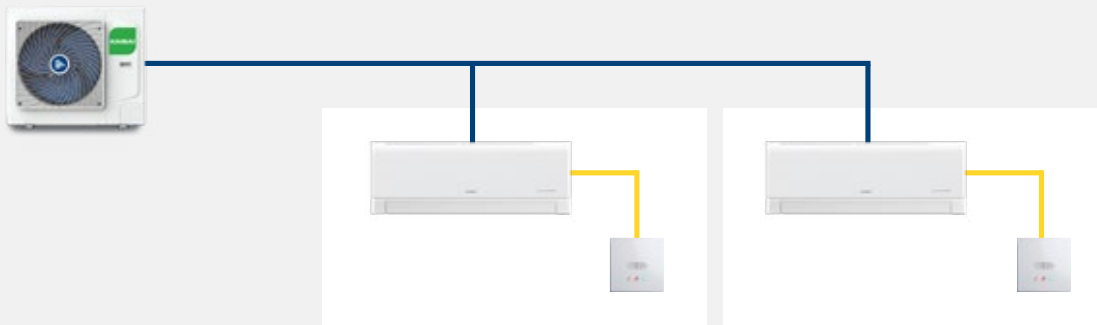

## Refrigerant leak detector components

The panel serves as the user interface, enabling quick assessment of the device status. It is equipped with LED indicators and an audible alarm that provide information about the current monitoring status.



### Visual Indication

Normal operation – Green LED ON continuously. The detector is operating correctly and continuously monitors the refrigerant concentration in the room.

Leak detected – Red LED flashing. The alarm threshold has been exceeded. The audible alarm and alarm outputs are activated.

Self-test fault – Yellow LED flashing. A device malfunction has been detected. Diagnostic inspection and verification of proper system operation are required.



### PCB Control Board

The PCB control board manages the operation of the entire device. It is responsible for signal processing, alarm control, and continuous monitoring of system performance.



### Buzzer

The buzzer generates an audible alarm with a sound level of 70 dB(A). Audible signaling supports visual alarms and improves the effectiveness of warning occupants.



### Sensor

The sensor continuously monitors refrigerant concentration in the air. When the alarm threshold of 10% LFL is exceeded, it sends a signal to the control board, initiating the alarm procedure.

## Conditions requiring additional safety measures

When refrigerants classified as A2L under EN 378 are used, additional safety measures are required. The assessment is based on the amount of refrigerant in the system and the room floor area. Based on these factors, it is possible to determine whether a particular system configuration requires additional protective measures. If the room area is below the minimum value for the given refrigerant charge, a shut-off valve set and a gas leak detection system must be installed.

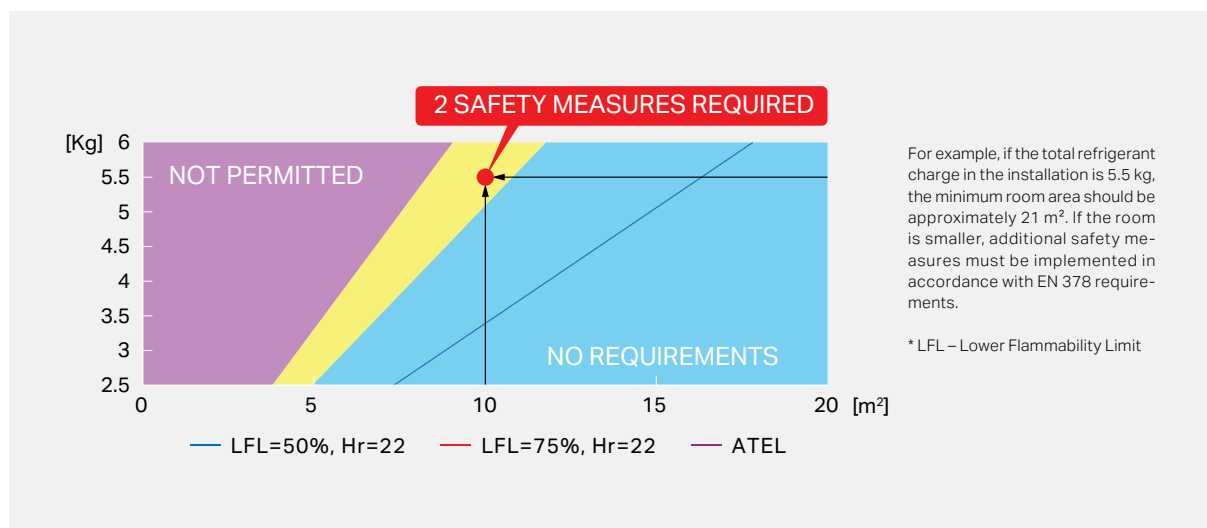

# DX-KIT



DX-KIT modules enable the integration of VRF systems with air handling units (AHUs) and chillers, including those from other manufacturers. They allow VRF units to be connected to heat exchangers in air handling units, enabling the effective use of direct expansion (DX) technology in ventilation systems. The use of DX-KIT modules significantly increases design flexibility and enables the integration of various HVAC systems. It is an ideal solution for modern commercial and industrial facilities where comprehensive and efficient indoor climate management is required. The DX-KIT module features a built-in expansion valve.

## Technical Specifications

Model		KWAARVK-00B	
Power supply		V~ / Hz / Ph	220~240 / 50~60 / 1
Capacity	Cooling (T1)	kW	9 kW–20 kW
EXV		pcs.	1
Electrical specifications	Max. current draw	A	1,0
	Power cord	mm <sup>2</sup>	3×2,5
Dimensions	Net dimensions (W×D×H)	mm	573×447×180
	Dimensions including packaging (W×D×H)	mm	655×525×250
Weight	Net weight	kg	11,2
	Gross weight	kg	13,8
Refrigeration pipes	Inlet	mm / (in.)	Φ 9,52 / (3/8)
	Outlet	mm / (in.)	Φ 9,52 / (3/8)
Operating temperature range		°C	16~32

# Branch pipes

Mini VRF system branch pipe are a set of two manifolds – one for the refrigerant gas line and one for the liquid line – designed for use in Kaisai mini VRF systems. These components enable the efficient distribution of refrigerant to multiple indoor units within a single installation. Kaisai manifolds are designed for independent diameter adjustment, ensuring high flexibility during system design and installation. They are available in various diameter ranges, making them easy to adapt to the specific requirements of a given installation. Each set is equipped with dedicated thermal insulation, which not only reduces energy loss but also significantly speeds up installation work and improves the aesthetic finish. As a result, the installation is more efficient, durable, and easier to service.



## Extended installation parameters

Kaisai mini VRF systems support installations up to 100 meters in length and with a height difference of up to 30 meters. This enables the effective cooling of large, multi-story buildings while maintaining a high degree of design flexibility.

## Two-pipe system

The 2-pipe refrigerant system with system tees in Kaisai mini VRF systems optimizes the layout of the entire installation. Shared refrigerant lines reduce the number of pipes, minimize material usage, and shorten installation time by eliminating the need for separate lines to each unit.

## Technical Specifications

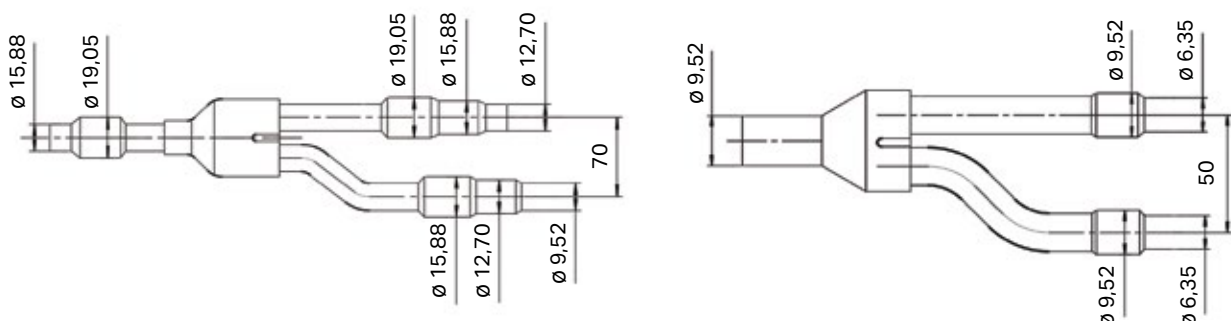

Model	KWAAFG-00B	
Package dimensions	mm	300×95×40
Net weight / gross weight	kg	0.31 / 0.35

# Contact Information

## For Consumers:

Are you interested in purchasing our products?  
Check the current list of distributors in Poland at: [www.kaisai.com](http://www.kaisai.com)

---

## For Distributors and Installers:

### HEADQUARTERS

101A Ostrobramska Street  
04-041 Warsaw  
+48 22 517 36 00 | +48 22 879 99 07

### SALES DEPARTMENT

+48 22 465 65 85  
[handlowy@kaisai.com](mailto:handlowy@kaisai.com)

### B2B PURCHASING PLATFORM

[sklep.kaisai.com](http://sklep.kaisai.com)

**Would you like to become one of our distributors? Email or call us.**

---

## Klima-Therm Group Academy:

### GDAŃSK BRANCH

48 Budowlanych Street  
80-298 Gdańsk  
+48 58 768 03 33

### WARSAW BRANCH

101A Ostrobramska Street  
04-041 Warsaw  
+48 22 517 36 00

### KATOWICE BRANCH

108 Chorzowska Street, Building B  
40-101 Katowice  
+48 32 209 49 26

---

This document is intended to provide information and present Kaisai brand devices. | The technologically advanced production process requires constant monitoring and improvement, therefore the information contained in this publication is subject to change. | The technical data contained in the catalog is subject to change. Current information is always available at: [www.kaisai.com](http://www.kaisai.com)

All technical data complies with the guidelines of standards EN14511; EN14825; EN50564; EN12102; (EU) No 811:2013; (EU) No 813:2013; OJ 2014/C 207/02:2014.  
The seasonal heating efficiency SCOP has been determined for moderate climate conditions.  
The sound power level in heating mode is specified in accordance with EN 12102 under conditions compliant with EN 14825.



[kaisai.com](https://kaisai.com)



**[kaisai.com](http://kaisai.com)**